



WALL UNITS

SWING GATE RACK

NUCOR[®]

DATA SYSTEMS

WALL UNITS

SWING GATE RACKS

WALL MOUNTED SWING RACK

- 19" wide rack mounting units
- Front swing gate hinges from either right or left
- Mounting rails tapped #10-32 on EIA standard spacing
- Integrated strain relief tie off points allow for flexible cable management
- 12 gauge steel construction
- Includes assembly hardware and rack screws
- Rear mounting holes provided on 16" centers for standard stud mounting
- Choice of colors: Color Code = "x" Black (BLK) or ASA 61 Gray (G)

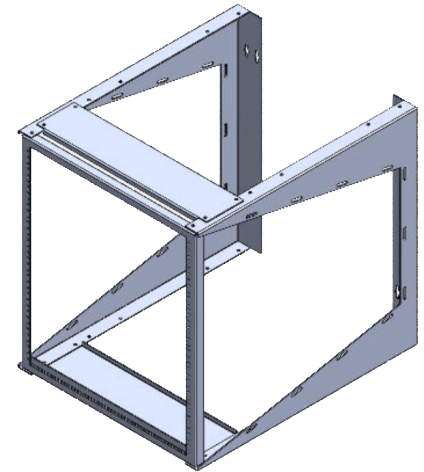

SWING GATE RACKS

PART NUMBER	HEIGHT/DEPTH	RMU	FITS LDF CABINET:
SWE2138-8x	22" X 8"D	11U	100 lbs.
SWE2138-12x	22" X 12"D	11U	100 lbs.
SWE2138-18x	22" X 18"D	11U	100 lbs.
SWE2138-25x	22" X 25"D	11U	100 lbs.
SWE2138-25-HD	22"H X 25"D Heavy Duty	11U	150 lbs.
SWE2139-8x	36" X 8"D	19U	100 lbs.
SWE2139-12x	36" X 12"D	19U	100 lbs.
SWE2139-18x	36" X 18"D	19U	100 lbs.
SWE2139-25x	36" X 25"D	19U	
SWE2139-25-HD	36"H X 25"D Heavy Duty	19U	150 lbs.
SWE2140-12x	48" X 12"D	26U	100 lbs.
SWE2140-18x	48" X 18"D	26U	100 lbs.
SWE2140-25x	48" X 25"D	26U	100 lbs.
SWE2140-25-HD	48"H X 25"D Heavy Duty	26U	150 lbs.

NUCOR[®]
DATA SYSTEMS

TEL: 909-796-6200

FAX: 909-796-6223

sales@nucordatasystems.com

1385 S Tippencanoe Ave., San Bernardino, CA 92408

NUCORDATASYSTEMS.COM