

Equipment Racks - 2 & 4 Post Racks

Adjustable Dual Equipment Rack

Features

- Heavy duty 12-gauge steel upright channels
- Extruded aluminum top and bottom angles
- 19" wide rack mount
- Front and rear mounting holes tapped #12-24 on EIA Standard spacing
- Variable depth is accomplished by adjusting depth spreader channels provided
- Designed with web channel holes to allow multiple racks to be mounted side by side
- Shipped unassembled and individually packaged
- Available in Black (BLK) powder coat finish

Part Number	Fits Rack #	Adjustable Depth
SWE04-841520BLK	84"H X 19" RM, 45U	15", 18", 20"
SWE04-842126BLK	84"H X 19" RM, 45U	21", 24", 26"
SWE04-842732BLK	84"H X 19" RM, 45U	27", 30", 32"

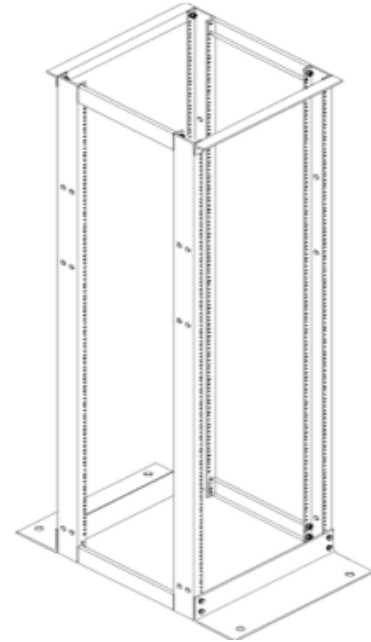

Adjustable Dual Rack

Adjustable Shelves

Features

- 19" four post equipment rack mount
- Formed 16-gauge steel construction
- Adjustable to fit specific rack depth
- Vented and non-vented versions available
- 200 lb. weight capacity
- Mounts to all four upright channels
- Available in Black (BLK) powder coat finish

Part Number	Fits Rack #	Adjustable Depth
SWE1520BLK	SWE04-841520BLK	15" to 20"
SWE2126BLK	SWE04-842126BLK	21" to 26"
SWE2732BLK	SWE04-842732BLK	27" to 32"

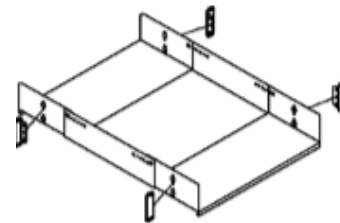

Adjustable Shelf

Note: Add "-V" to part number for vented version e.g., SWE1520-VBLK

Equipment Racks - 2 & 4 Post Racks

Dual Server Rack Frame

Features

- Heavy duty 12-gauge steel upright channels
- Extruded aluminum top and bottom angles
- 19" wide rack mount
- Available in 2 depths
- Unequal flange upright channels punched with Cage Nut Holes on EIA Standard spacing
- 84" high
- 1000 lb. weight capacity—evenly distributed
- Designed with web channel holes to allow multiple racks to be mounted side by side
- Includes:
 - Bag of (24) #12-24 Cage Nuts and screws
 - Bag of (24) M6 Cage Nuts and screws
- Ships unassembled and individually packaged
- Available in Black (BLK) powder coat finish

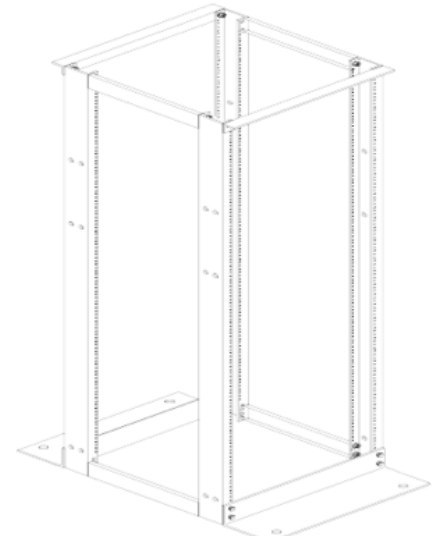

SWE04-8419CNBLK

Part Number	Description
SWE04-8419CNBLK	4 Post Rack, 29" deep, Cage Nut
SWE04-841930CNBLK	4 Post Rack, 30" deep, Cage Nut
SWE04-841936CNBLK	4 Post Rack, 36" deep, Cage Nut

Conversion Kit: SWE04-CK2732BLK

Features

- Converts single equipment rack (SWE570BLK) to adjustable rack (27" to 32")
- Includes (2) upright channels, top and bottom adjustable spreaders, hardware to install
- Black (BLK) powder coat finish

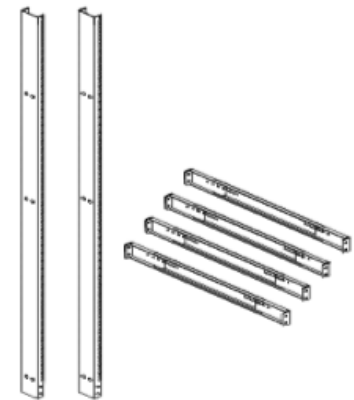

SWE04-CK2732

Equipment Racks - 2 & 4 Post Racks

Equipment Racks: SWE570 Series

Features

- Heavy duty steel upright channels
- Extruded aluminum top and bottom angles
- 19" and 23" wide rack mounts
- Front and rear upright mounting holes tapped #12-24 on EIA Standard spacing
- Supplied with (2) top angles for additional strength
- 750 lb. weight capacity—evenly distributed
- Designed with web channel holes to allow multiple racks to be mounted side by side
- Includes bag of (50) #12-24 mounting screws
- Shipped unassembled and individually packaged
- Choice of colors: Color Code = "x" Black (BLK) or ASA 61 Gray (G)

19" RM	23" RM	Height	RMU
SWE570x	SWE570-23x	84"	45U
SWE571x	SWE571-23x	68"	36U
SWE572x	SWE572-23x	48"	24U
SWE573x	SWE573-23x	96"	52U
SWE575x	SWE575-23x	108"	58U

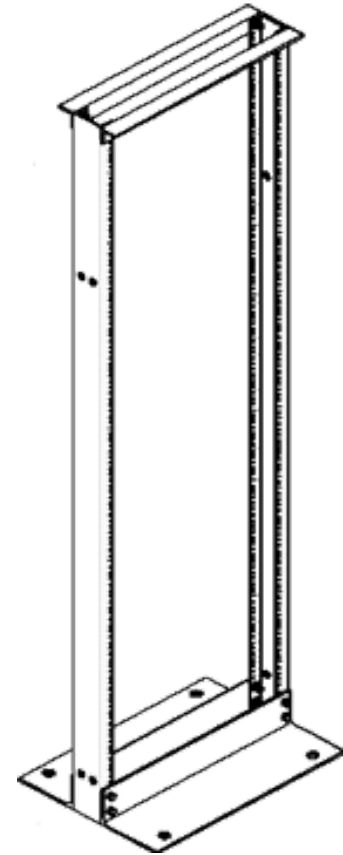

SWE570